



TFS PRODUCT

SAMPLE STATION

For safe extraction of oil for testing

Most thermal fluid systems operate above the fluids CCFP and must be treated on a risk assessment basis. Thermal fluids must therefore be sampled regularly and tested to determine Closed Cup Flash Point. Since volatile components (including water) will evaporate if the fluid is exposed to atmosphere close to or above their boiling point, the sample must be removed at low temperature.

OVERVIEW

The TFS Sample Station is designed for the safe and convenient removal of a sample of fluid from thermal fluid systems. Fluid is drawn from the system and allowed to cool whilst excluding air.

The assembly is mounted on a free-standing back plate with integral bund and protective mesh so that it can be used free standing or system mounted. The vessel utilises ambient cooling so does not need a cooling water

supply, giving more flexible connection options. Standard connection to the unit is 1/2" compression fitting. User specified connections can be provided if required.

The unit incorporates a thermowell mounted thermometer which is primarily intended to show when the fluid sample is cool enough to release into the sample bottle but is also an indication of when hot (representative) fluid is present in the sample chamber.

The unit is certified as a pressure vessel and conforms to PED rated at 10 Bar and 350°C. Pipework is 304 stainless steel with compression fittings throughout which allow period inspection, maintenance and cleaning.



SUITABLE FOR ALL SITUATIONS

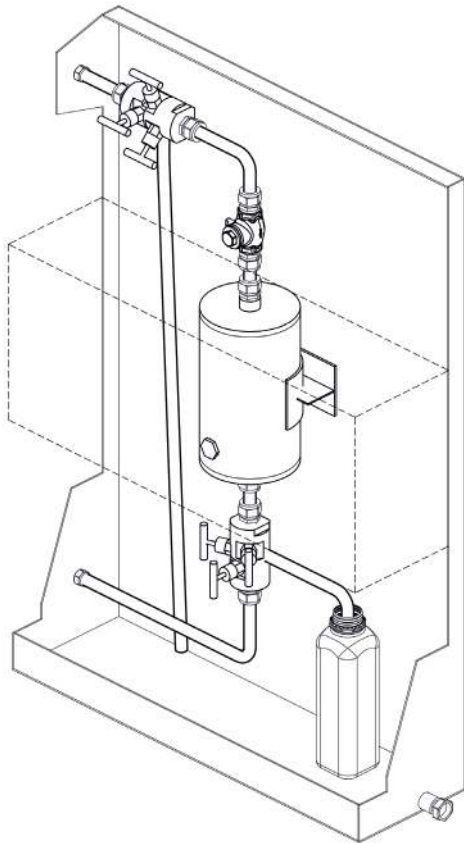

The sample chamber is certified to PED and ASME viii, rated to 10 Bar and 350°C (660°F). The unit is manufactured from Stainless Steel with compression fittings throughout that allow periodic inspection, maintenance and cleaning.

Our recommended configuration has both an inlet and an outlet connection to the host system and essentially takes a side stream of the host fluid. Fluid is drawn from the system and allowed to cool whilst excluding air. The use of both inlet and outlet connections to the unit means that hot fluid or vapour does not need to be vented from the system to obtain a representative sample. High temperature needle valves are utilised on the inlet and outlet in industry standard double block and bleed configuration. Once isolated from the system and cool, a sample can be drawn easily and safely into the sample collection bottle.

TFS offers a sampling, testing and analysis service whereby we can arrange to supply sample bottles, have them collected by our courier and tested through our own dedicated lab. A full report is then provided. In North America, this service is provided by our partner LTI Group.

